

DOWNSTREAM ELEVATION

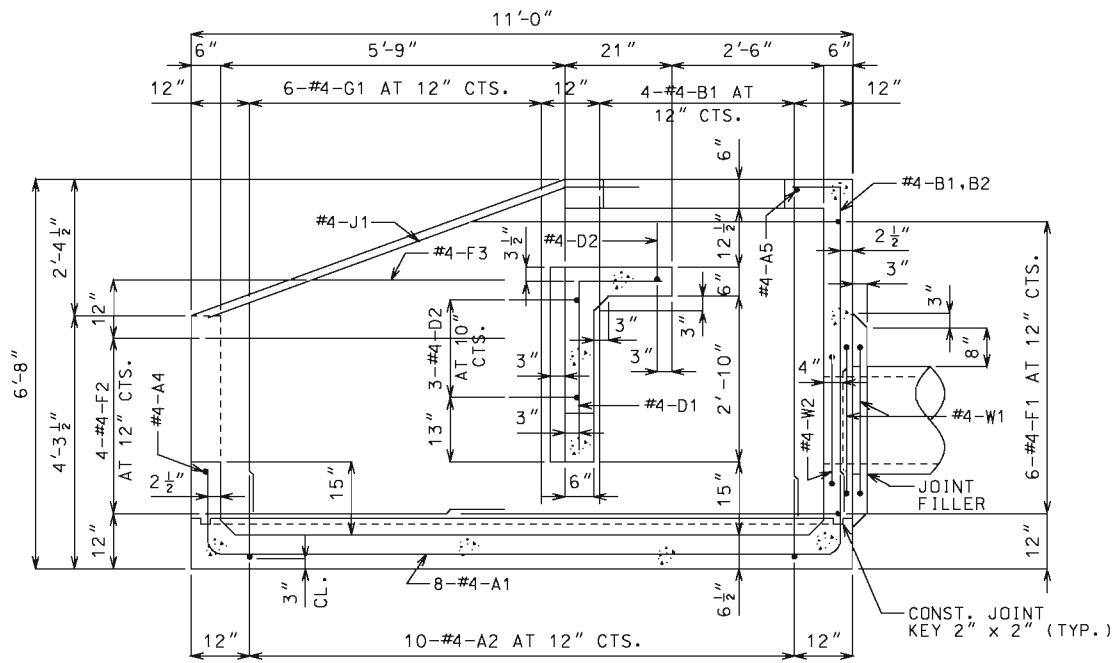

SECTION A - A

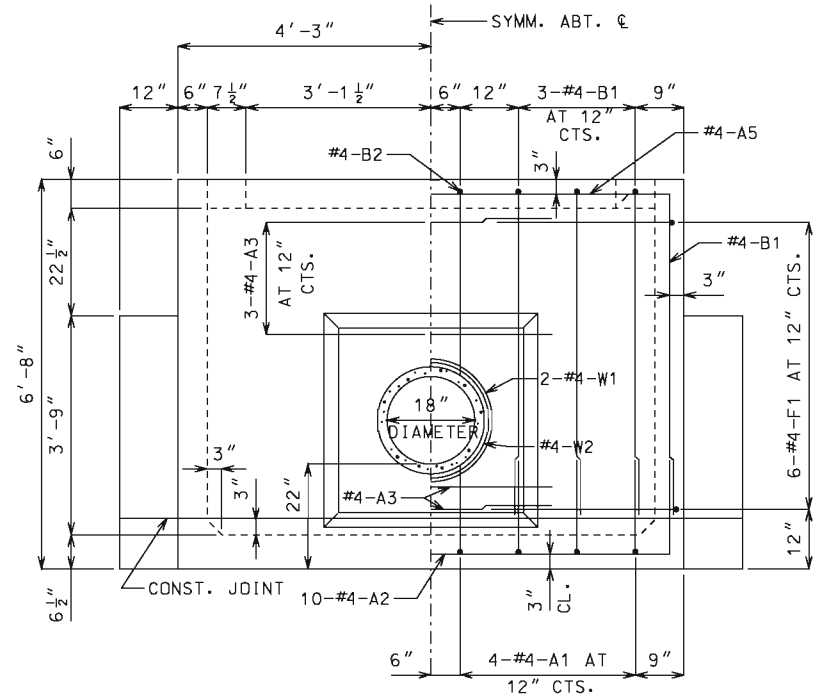

UPSTREAM ELEVATION

NOTE: BEND OR CUT A1 BARS IN FIELD TO CLEAR PIPE.

**GENERAL NOTES:**

**DESIGN UNIT STRESSES**

CLASS B CONCRETE  $f'c = 3,000$  psi  
 REINFORCING STEEL (GRADE 60)  $f_y = 60,000$  psi

**REINFORCING STEEL**

MINIMUM CLEARANCE TO REINFORCING STEEL SHALL BE  $1\frac{1}{2}$ " UNLESS SHOWN OTHERWISE.

**DIMENSIONS**

DRAWINGS ARE NOT TO SCALE. FOLLOW DIMENSIONS.

**ESTIMATED QUANTITIES**

ITEM	CU. YD.	TOTAL
CLASS B CONCRETE	6.1	
REINFORCING STEEL	490	

**COMPLETE BILL OF REINFORCING STEEL**

NO.	REQ'D	MARK NO.	SHAPE NO.	VARIES (V)	DIMENSIONS								NOMINAL LENGTH	ACTUAL LENGTH	WEIGHT
					NO. EACH										
					B	C	D	E	F	H	K				
8	4	A1	11			0-16 $\frac{1}{2}$	10-7	0-17 $\frac{1}{2}$				13-5	13-3	71	
10	4	A2	11			0-18 $\frac{1}{2}$	8-0	0-18 $\frac{1}{2}$				11-1	10-10	72	
5	4	A3	20			4-6						4-6	4-6	15	
1	4	A4	20			10-3						10-3	10-3	7	
1	4	A5	20			8-3						8-3	8-3	6	
14	4	B1	19			5-9	0-9					6-6	6-4	59	
2	4	B2	19			2-11	0-9					3-8	3-6	5	
7	4	D1	19			2-11	0-16					4-3	4-2	19	
4	4	D2	11			0-20 $\frac{1}{2}$	8-0	0-20 $\frac{1}{2}$				11-5	11-3	30	
1	4	D3	15			2-1 $\frac{1}{2}$	2-11 $\frac{1}{2}$	2-1 $\frac{1}{2}$	0-21 $\frac{3}{8}$	0-13 $\frac{1}{2}$	0-21 $\frac{3}{8}$	7-3	7-2	5	
2	4	D4	14			0-12	0-6	2-1 $\frac{1}{2}$			0-21 $\frac{3}{8}$	3-8	3-6	5	
2	4	E1	23			0-13	4-0 $\frac{3}{8}$				0-9 $\frac{3}{8}$	5-1	5-1	7	
12	4	F1	19			2-10 $\frac{1}{2}$	6-4 $\frac{3}{8}$					9-3	9-1	73	
8	4	F2	19			0-13	5-9					6-10	6-9	36	
2	4	F3	20			4-0						4-0	4-0	5	
12	4	G1	20	V	2	5-8						5-8	5-8	38	
						3-9	(INCREMENT = 4 $\frac{3}{8}$ INCHES)					3-9	3-9	38	
2	4	J1	20			7-5						7-5	7-5	10	
2	4	J2	19			3-10 $\frac{1}{2}$	2-1 $\frac{1}{2}$					6-0	5-11	8	
2	4	W1	16			2-4						8-2	8-2	11	
1	4	W2	16			0-23						6-11	6-11	5	

**BENDING DIAGRAMS**

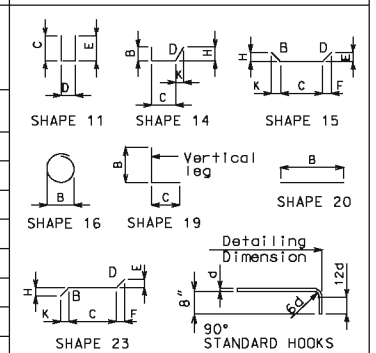

ALL STANDARD HOOKS AND BENDS OTHER THAN 180 DEG. TO BE BENT WITH SAME PROCEDURE AS FOR 90 DEG. STANDARD HOOKS.  
 HOOKS AND BENDS SHALL BE IN ACCORDANCE WITH THE PROCEDURES AS SHOWN ON THIS SHEET.  
 NOMINAL LENGTHS ARE BASED ON OUT TO OUT DIMENSIONS SHOWN IN BENDING DIAGRAMS AND ARE LISTED FOR FABRICATORS USE.  
 PAYWEIGHTS ARE BASED ON ACTUAL LENGTHS.  
 LENGTH = TOTAL LENGTHS ARE MEASURED ALONG CENTERLINE BAR TO THE NEAREST INCH.  
 V = BAR DIMENSIONS VARY IN EQUAL INCREMENTS BETWEEN DIMENSIONS SHOWN ON THIS LINE AND THE FOLLOWING LINE.  
 NO.EA. = NUMBER OF BARS OF EACH LENGTH.

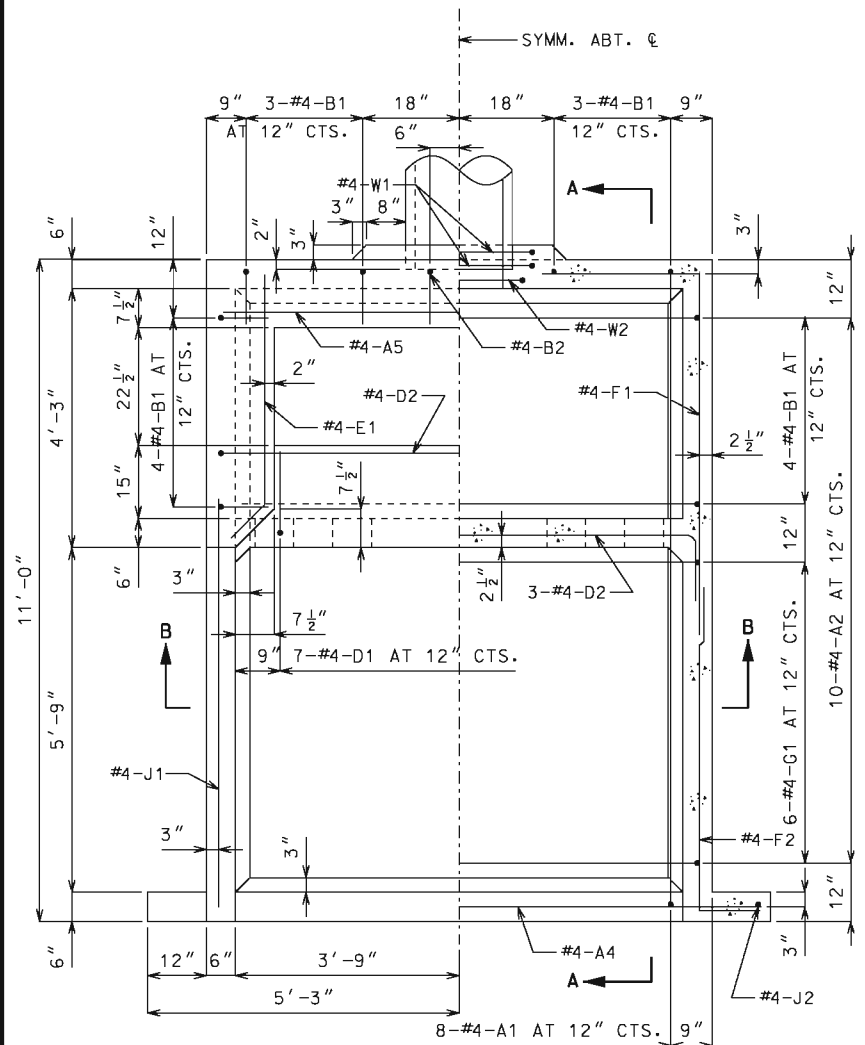

HALF PLAN HALF HORIZONTAL SECTION

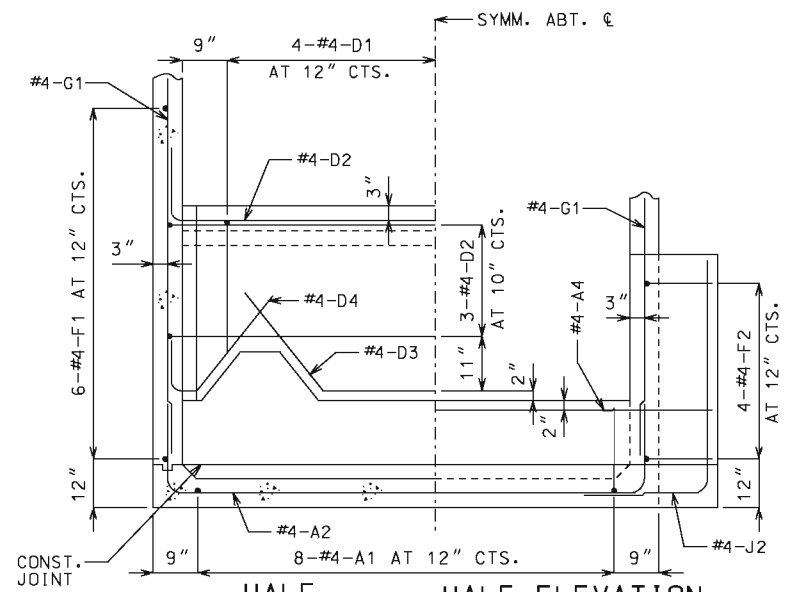

HALF SECTION B-B HALF ELEVATION OF LOWER BAFFLE AND WING

NOTE: BEND OR CUT D1 BARS IN FIELD TO CLEAR NOTCH IN BAFFLE WALL.

**MISSOURI HIGHWAYS AND TRANSPORTATION COMMISSION**  
 105 WEST CAPITOL JEFFERSON CITY, MO 65102  
 1-888-ASK-MODOT (1-888-275-6636)

**STATE OF MISSOURI**  
 DENNIS W. HECKMAN  
 NUMBER PE-27141  
 PROFESSIONAL ENGINEER

**PIPE CULVERT HEADWALL ENERGY DISSIPATOR (IMPACT TYPE) FOR 18" CONCRETE PIPE**

DATE EFFECTIVE: 07/01/2001  
 DATE PREPARED: 9/3/2009

**604.10E**

SHEET NO. 1 OF 1

IF A SEAL IS PRESENT ON THIS SHEET IT HAS BEEN ELECTRONICALLY SEALED AND DATED.